



Installation and Operation Manual
(IU-0023-EN-201004)

TANK
FOR PRODUCTION AND STORAGE
OF DOMESTIC HOT WATER

Preference
RC 951 range

FOREWORD

Dear customer,

Thank you for choosing a LACAZE ENERGIES Preference range Domestic Hot Water tank type RC951.

In your own interest, we invite you to follow and to observe the instructions given in this manual and to ensure that the required maintenance is carried out by qualified personnel, in order to maintain the appliance at its maximum efficiency level.

We remind you that failure to comply with the instructions contained in this manual will result in invalidation of the warranty.

The manufacturer cannot be held responsible in any case of damage to persons, animals or objects due to failure to comply with the instructions contained in this manual and supplied with the equipment.

SUMMARY

GENERAL INFORMATION.....	4
TECHNICAL FEATURES.....	9
INSTALLATION	20
CHECKING AND MAINTENANCE	26
WARRANTY.....	27
PACKING/TRANSPORT/STORAGE/HANDLING	29
ANNEX.....	30

GENERAL INFORMATION

Symbols used in this manual

While reading this manual, particular attention must be paid to the paragraphs preceded by the following symbols:



DANGER!
Dangerous situation
for the user



GENERAL DANGER
Potentially dangerous situation
for the product and
environment



RISK OF DEFORMATION
Due to pressure variations
(Variation limited to 1 bar)



NOTE!
Note / Warning
for the user



**LIMIT OF OPERATIONAL
TEMPERATURE**
(Maximum value **in pick**= 95°C)

Note concerning the elaboration and publication of this manual



NOTE !

This manual was elaborated and published under the direction of LACAZE ENERGIES. It covers the most recent and known to date features and descriptions of the products.

The manual content and the products features may be modified without prior notice.

LACAZE ENERGIES reserves the right to modify without prior notice the features and elements contained in the following pages. LACAZE ENERGIES will not be responsible for any damage (including consecutive damage) caused by reliance on the presented elements. This includes, but is not limited to, typing and translating mistakes and other errors linked to the publication.

© 2009 LACAZE ENERGIES

Quality of supply water (fill and top up)

Water tanks in the « **Preference RC951 range** » are designed for the storage and production of domestic hot water. Consequently, the supply water (fill and top up) must be of drinking water quality intended for human consumption. **Any other application must be notified to us by recorded mail and authorized by the manufacturer before installation.**

In order to best protect the tank and to benefit from the manufacturer's warranty, it is imperative to use a quality of fill and top up water which conforms to the recommendation of DTU N° 60.1 - Additif N° 3 (see Annex). Otherwise, a complementary water treatment is required if this is found to be in one or several of the conditions below (measured at 20°C):

Resistance < 2 200 Ω.cm	Resistance > 4 500 Ω.cm	CO ₂ free > 15 mg/l (ppm)
TH < 8 °F	TAC < 8 °F	Sulphates (SO ₄ ²⁻) > 96 mg/l
Chlorine (Cl-) > 71 mg/l	SO ₄ ²⁻ + Cl- < 15 °f	Scale RYZNAR > 8

For information, one French degree (°f) = 0,2 meq per liter.



NOTE !

The balance of the calcium-carbonic system in the drinking water can be described by the following equations:

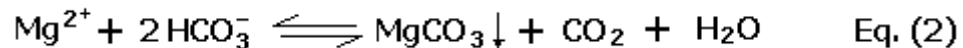
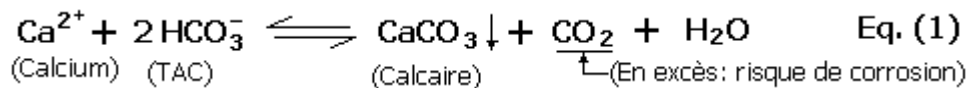

In general, the total hardness (TH) of the water is composed of the content of Calcium for a percentage of 85-95% and that of Magnesium (Mg) for 5-15%.

The Ryznar index is largely used to characterize the nature of the water (Stability Index) in installations for heating and production of domestic hot water. This index allows the aggressive or scaling tendency of aerated water to be described. It is defined as follows :

IR = 2 pHs - pHm; where

- pHs : pH of the water at equilibrium to be calculated (or as per marble test)
- pHm : measured pH of water

For water at equilibrium point, the Ryznar index = 6,67. See below the table which allows to qualify the nature of water according to the Ryznar index:

IR Value	Tendency
4 to 5	Important scaling
5 to 6	Slight scaling
6 to 7	Equilibrium
7 to 7,5	Slight corrosiveness
7,5 to 8,5	Noticeable corrosiveness
> 8,5	Important corrosiveness

The ideal value of the supply water at 20°C (IR) is situated between 7 and 8 because this index decreases with the increase in temperature.

Another aspect related to the corrosiveness of the water is the presence of chlorides (Cl⁻) and of sulphates (SO₄²⁻) in the water, known as «corrosion accelerators» (detail: see **Larson Index**). This is why the stability of the water described by the IR must be supervised as well as the content of chlorides and sulphates.

Information to be given to the user



NOTE !

This instruction manual, and any other documentation relating to the appliance, is an integral part of the product and must imperatively be given to the user, ***who must keep the documents in an accessible place to be consulted when needed.***

Warning

The appliance was destined for the storage and production of domestic hot water. Any other unauthorized use shall be considered improper and dangerous.

The appliance must not be installed in humid locations (H.R. ≤ 80%). Protect the appliance from water or other liquid splashes to prevent damage to the components.

The installation must be carried out in compliance with the rules, regulations and standards currently in force at the place of installation, observing the manufacturer's instructions and by a qualified professional.

In the case of the equipment being sold or transferred to another user, this manual must accompany the equipment, so that the new user and the installer can consult it.

In the case of the equipment not being used during a period of below-freezing conditions, we recommend that it should be completely drained. The manufacturer declines all responsibility for any damage due to frost.

We strongly recommend that these instructions be read carefully before commencing any operation, such as installation, commissioning, maintenance, etc.

Data plate

a) metal jacket



b) flexible PVC jacket

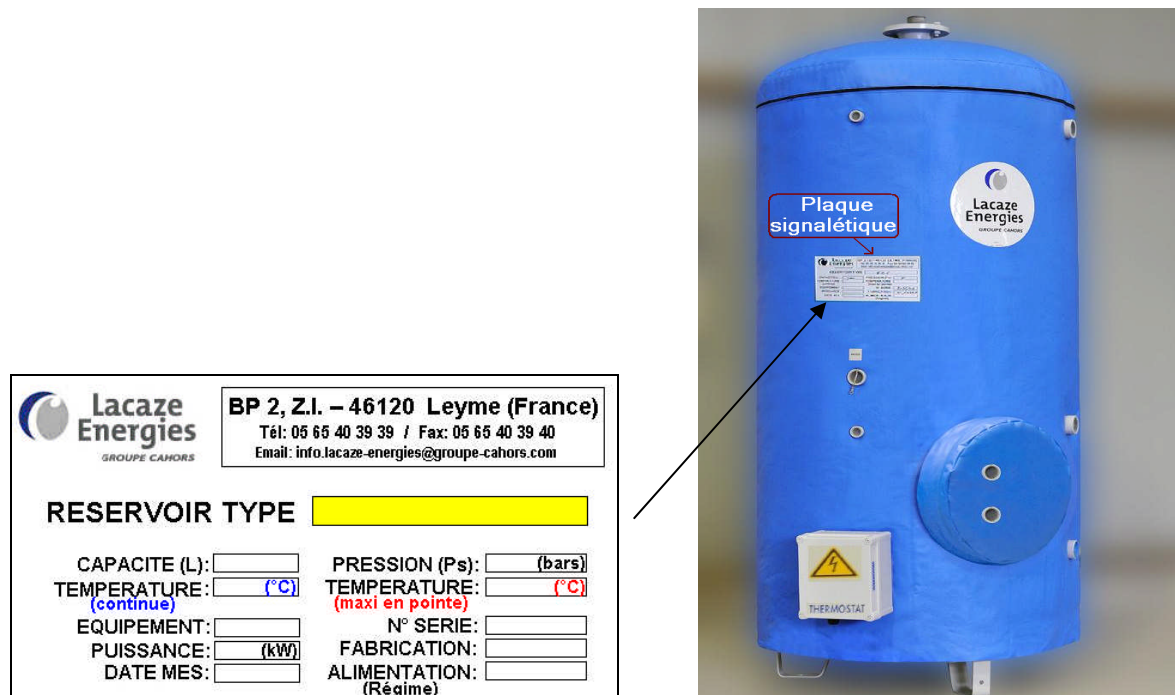

Security warnings



WARNING!

The installation, adjustment and maintenance of the appliance must be carried out by a qualified professional in compliance with the rules, regulations and standards in force.



DANGER!

Maintenance work or eventual repairs to the appliance must be carried out by a qualified professional or person approved by the manufacturer. We strongly recommend that the appliance be covered by a yearly maintenance contract from the first year of operation.

Insufficient or irregular maintenance can compromise the operational security of the appliance and cause damage to persons, animals or objects for which the manufacturer can in no case be held responsible (e.g. scale on the thermostat and/or valve.)

The exclusive use of spare parts supplied by the manufacturer is strongly advised in order to obtain the best service from the product and the acknowledgement of the product warranty.



WARNING!

To tighten and loosen the appliance connections, especially the manhole cover plate, use only appropriate wrenches (e.g. torque wrench). Nonconformity of use (joints, bolts, tightening torque etc.) and/or inappropriate tools can cause serious damage (e.g. leakages).



NOTE !

By «Qualified Professional», we understand a person possessing technical knowledge in the field of components and of heating / production of domestic hot water (DHW) installations.

TECHNICAL FEATURES

Tanks

The « **Preference 951 range** » of vertical tanks to which this manual applies concerns capacities from 300 to 6 000 liters. The range is intended for the production and storage of domestic hot water (DHW).

Description of tanks:

The tanks are made of 1st quality steel. The design and fabrication is based on regulations in force (EPD 97/23/CE and CODAP) and over 50

years of the company's experience in the field of tank manufacturing.

The interior of the tanks (interior wall) is protected (covered) with a food-grade class coating RC951, which has an ACS Certificate (Health Conformity Attestation) published on the list of the Ministry of Health, Youth and Sports – Category « Revêtements à base de résine époxydique disposant d'une ACS » - Version March 2008 and also a "WRAS approved" Certification.

The outside of the tanks is protected against corrosion by a single or double coat of anti-rust paint.

Dimensions of tanks

Plan of principle and Key:

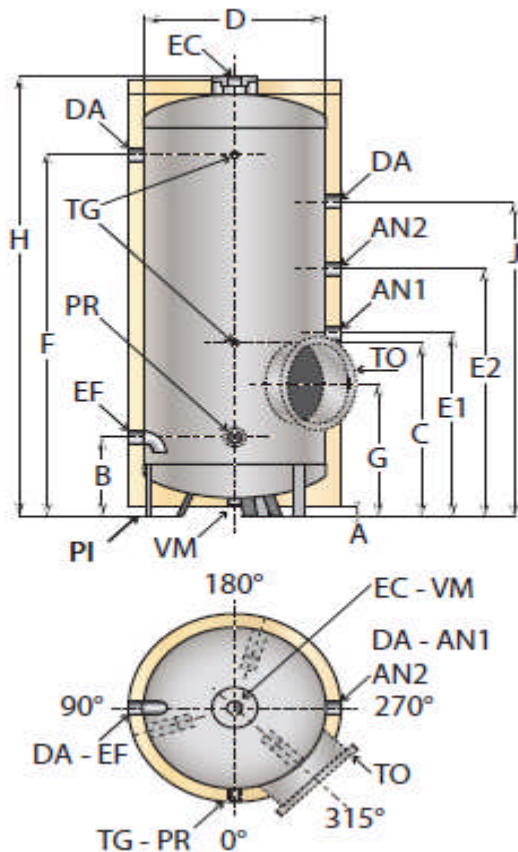

- EF : Cold water inlet with baffle (coupling 50/60)
- EC : Hot water outlet : (coupling 50/60)
- DA : Loop exit/entry (couplings 50/60)
- VM : Drainage (threaded coupling 50/60)
- TG : Couplings 15/21 for thermometer and thermostat
- PR : Threaded ring M77 for mounting of immersion heaters (applies only to versions without manhole)
- AN1 : Coupling 40/49 for anode
- AN2 : Coupling 40/49 for 2nd anode (from 4000L)
- TO : Manhole Ø int. 400mm (nozzle Ø int. 250mm on 300L)
- PI : Supporting feet

Capacities and Dimensions:

Capacity (litres)	A (mm)	B (mm)	C (mm)	D (mm)	E1 (mm)	E2 (mm)	F (mm)	G (mm)	H (mm)	J (mm)	Wght (kg) W/O Tube h.	Wght (kg) with Tube h.
300	110	395	685	550	750	---	1.155	565	1.480	995	80	---
500	110	410	860	650	925	---	1.420	660	1.760	1.170	100	145
750	110	440	890	800	955	---	1.450	690	1.820	1.200	155	200
1.000H	110	440	890	800	955	---	2.000	690	2.370	1.510	175	225
1.000B	110	475	925	950	990	---	1.485	725	1.890	1.235	175	225
1.500H	110	475	925	950	990	---	2.035	725	2.440	1.545	215	270
1.500B	110	510	960	1.100	1.025	---	1.520	760	1.960	1.270	215	270
2.000H	110	510	960	1.100	1025	---	2.070	760	2.510	1.580	380	425
2.000B	110	560	1.010	1.300	1.075	---	1.570	810	2.060	1.320	380	425
2.500	110	560	1.010	1.300	1.075	---	1.820	810	2.310	1.430	435	480
3.000	110	560	1.010	1.300	1.075	---	2.120	810	2.610	1.630	480	540
4.000	140	630	1.060	1.500	1.125	1.550	2.185	860	2.715	1.805	680	780
5.000	140	630	1.060	1.500	1.125	1.875	2.805	860	3.335	2.155	790	910
6.000	140	630	1.060	1.500	1.125	2.125	3.305	860	3.835	2.485	890	1.030

General tolerances ± 30 Tolerance on H : [± 60]

Operational Data

Capacities and Heating Power:

Capacity (liters)	Electrical Power (kW) DHW = 10/60°C in 6H		Tube Heater DHW 10/60°C (RP = 90/70°C)	
	Immersion Heater	Pockets (n x kW)	Heater only P(kW)-T(h)	Combined P(kW)-T(h)
300	3 (1 X 3)	---	---	---
500	6 (1 X 6)	4,5 (1 x 4,5)	11,2 - 2	7,5 - 3
750	9 (1 X 9)	6 (1 x 6)	17,3 - 2	11,5 - 3
1.000	12 (1 X 12)	7,5 (1 x 7,5)	25,2 - 2	16,8 - 3
1.500	15 (1 X 15)	15 (6 + 9)	34,0 - 2	22,6 - 3
2.000	20 (1 X 20)	18 (3 x 6)	48,4 - 2	32,3 - 3
2.500	24 (1 X 24)	27 (3 x 9)	58,0 - 2	38,6 - 3
3.000	30 (1 X 30)	27 (3 x 9)	69,4 - 2	46,3 - 3
4.000	40 (2 X 20)	36 (4 x 9)	95,5 - 2	63,7 - 3
5.000	48 (2 X 24)	45 (5 x 9)	126,9 - 2	84,6 - 3
6.000	60 (2 X 30)	54 (6 x 9)	152,3 - 2	101,5 - 3

Cathodic protection:

The standard NF EN12499 applies to the internal cathodic protection of domestic water heaters, hot and cold water storage tanks etc. whose metallic structures contain accumulated or circulated, dormant or renewed, hot or cold, drinkable or industrial water, as well aqueous suspensions having the following characteristics (*article 10.3*):

- temperature: (2 -98 °C) (see EN60335-2-21)
- conductivity: > 10 mS/m at 20°C (100 µS/cm)
- pH value: > 5,5

In conformity with this standard, the cathodic protection of « Preference 951 range» tanks by Magnesium anode (number of anodes, their dimension and positioning) has been conceived and determined according to the tank geometry. The table below gives a standard configuration of this cathodic protection:

Type	Diameter	Anode	Initial Weight	Min. quantity required	Positioning
300S	Ø 550	Ø 32 x 500 T 1"1/2	700 g	1	AN1
500S	Ø 650	Ø 32 x 500 T 1"1/2	700 g	1	AN1
750S	Ø 800	Ø 32 x 700 T 1"1/2	980 g	1	AN1
1000H	Ø 800	Ø 32 x 700 T 1"1/2	980 g	1	AN1
1000B	Ø 950	Ø 32 x 700 T 1"1/2	980 g	1	AN1
1500H	Ø 950	Ø 32 x 700 T 1"1/2	980 g	1	AN1
1500B	Ø 1100	Ø 32 x 900 T 1"1/2	1 260 g	1	AN1
2000H	Ø 1100	Ø 32 x 900 T 1"1/2	1 260 g	1	AN1
2000B	Ø 1300	Ø 32 x 900 T 1"1/2	1 260 g	1	AN1
2500S	Ø 1300	Ø 32 x 900 T 1"1/2	1 260 g	1	AN1
3000S	Ø 1300	Ø 32 x 900 T 1"1/2	1 260 g	1	AN1
3000X	Ø 1400	Ø 32 x 900 T 1"1/2	1 260 g	1	AN1
4000S	Ø 1500	Ø 32 x 900 T 1"1/2	2 520 g	2	AN1et AN2
5000S	Ø 1500	Ø 32 x 900 T 1"1/2	2 520 g	2	AN1et AN2
6000S	Ø 1500	Ø 32 x 900 T 1"1/2	2 520 g	2	AN1 et AN2

Note : *The tanks are equally ready to receive at least one anode Ø40 x 600 T1"1/2 from 500S.*

Anode mounting:

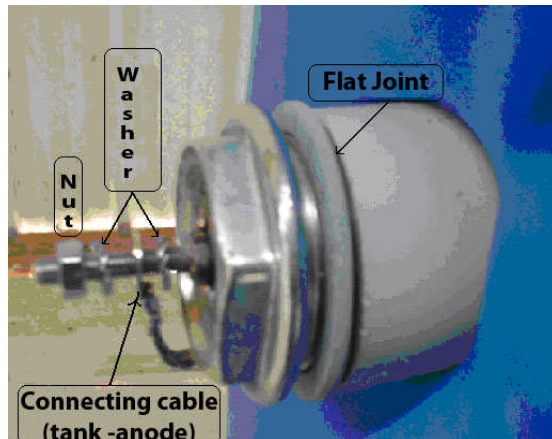

(old version)

In order for the cathodic protection to be efficient, a good connecting contact between the anode and the body of the tank to be protected is indispensable. Our anode is always delivered with a packet containing:

- 1 flat joint
- 2 anti-turn washers
- 1 nut

These must be assembled according to the example opposite.

However, it is recommended to ensure water tightness with traditional methods (insulating compound, fiber, Teflon etc.)



Warning!

For all non-standard product (NS), refer to the specific data sheet concerning the dimensions (plans) and operating data accompanying the delivered product.

Latest generation anode (new version)

Principle:

On opening the valve ❶, the escape of water by ❷ signifies the total consumption of the anode.

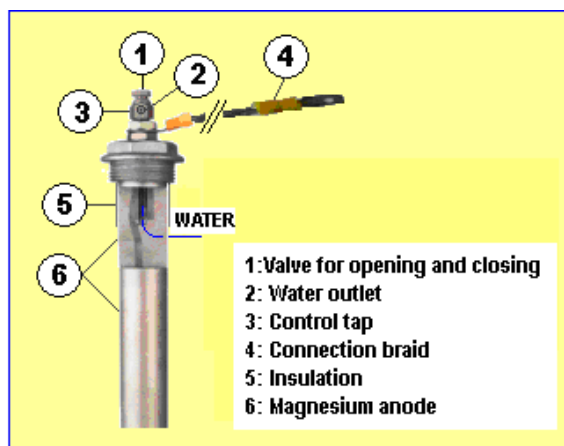

The main advantage of this anode is its simplicity:

- Maintenance: monitoring of wear without the need to dismantle the anode or empty the tank.
- Fast and efficient connection enabling the assembly and dismantling of the anode, as well as effective protection

Mounting :

Please find below an example of mounting:

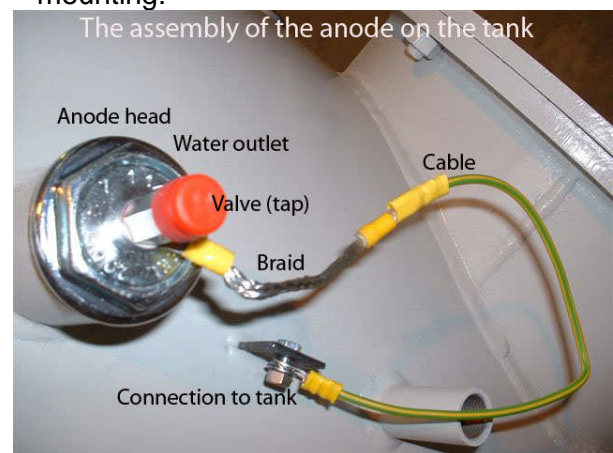

WARNING: Do not forget to well close the valve of the tap carefully once the tank is filled with water. **Never allow water to flow over the instruments / electrical equipment installed below (Danger!)**

Warnings



Tanks are conceived for a maximum and relatively constant service pressure of 7 bars. The extent of pressure variations must be limited to 1 bar.



Maximum operating temperature for CR951 coating is 95°C.



NOTE!

According to the 30.11.05 decree and in order to limit the risk of burns (applicable in France, please refer to similar legislation applicable at the place where the equipment is installed):

(<http://www.legifrance.gouv.fr/affichTexte.do?cidTexte=JORFTEXT000000423756&dateTexte>)

- in rooms destined for toilets, the maximum temperature of domestic hot water is fixed at 50°C at the water drawing points;
- in all other rooms, the temperature of domestic hot water is limited to 60°C at the water drawing points.

According to the circular DGS n°2002/243 of 22.04.2002 :

(<http://www.sante.gouv.fr/adm/dagpb/bo/2002/02-18/a0181819.htm>)

- The temperature of water at the exit from the tank must permanently be superior to 55°C.
- Daily elevation of tank temperature above 60°C.

According to the decree of 30.11.2005 and in order to limit the risk related to the development of Legionnaire's disease (applicable in France, please refer to similar legislation applicable at the place where the equipment is installed): :

- when the total volume of storage equipments is superior or equal to 400 liters, the water contained in the storage equipment, with the exception of the preheating tanks, must:
 - be permanently at a temperature superior or equal to 55°C at the equipments' outlets;
 - or be raised to a sufficient temperature at least once every 24 hours, under reserve of permanently respecting the dispositions set out in the first paragraph of the present article.

Thermal insulation

In standard version, two types of insulation are proposed:

- Glass wool Naturol (32 kg/m³) or equivalent, thickness 60 mm and PVC jacket, fire rating M1.
- Rock wool 40 kg/ m³, thickness 50 mm or 100 mm and metal sheet jacket (Aluminum quality 3105 or 3005, filmed on one side), fire rating M0.

It must be noted that in standard version, the inferior dished end is also insulated (up to diameter Ø 1300) as well as the manhole and/or the Ø 250 mm nozzle.

Optional:

- Rock wool 16 kg/m³, thickness 50 mm and glass fabric jacket, fire rating M0.
- Bottom dished end insulation, in expanded high insulating quality foam PUR ($\lambda = 20 \text{ mW}/(\text{m.K})$, thickness 40mm (other thicknesses possible).



Warning!

Concerning the protective film on the metal sheet jacket, this must be removed as soon as possible. In case of prolonged exposure to ultraviolet rays, the film may become difficult to remove.

Thermal Insulation Performances:

The thermal loss (heat loss) through storage is calculated against a cooling constant (Cr) in Watts.hour per liter per Kelvin and per day. According to the dimensions of our tanks with Naturol 032 insulation ($\varnothing = 0,032$ W/(m.K), Lambda thermal insulation conductivity coefficient), the results of the Cr calculation are set out in the following table:

Tank cooling constants (CR)				
Tanks		Glass wool Naturol		
		Thickness 60	Thickness 100	
Models	D (mm)	CR 60 (Wh/day.K.L)	CR 100 (Wh/day.K.L)	
300	550	0,125	0,077	
500	650	0,098	0,060	
750	800	0,080	0,049	
1000H	800	0,075	0,046	
1000B	950	0,068	0,042	
1500H	950	0,063	0,039	
1500B	1100	0,060	0,037	
2000H	1100	0,055	0,034	
2000B	1300	0,052	0,032	
2500	1300	0,050	0,031	
3000	1300	0,048	0,030	
4000	1500	0,042	0,026	
5000	1800	0,040	0,025	
6000	1900	0,039	0,024	



NOTE !

According to the Thermal Regulations of 24.05.2006 (RT 2005): (applicable in France, please refer to similar legislation applicable at the place where the equipment is installed), the electric accumulation water heaters must have a cooling constant inferior or equal to:

- $Vs \leq 500 \text{ L} : Cr = 1,25 \times Vs^{-0,33}$
- $Vs > 500 \text{ L} : Cr \leq 2 \times Vs^{-0,4}$

Examples : $Vs = 300\text{L} \rightarrow Cr = 0,190$; $Vs = 750\text{L} \rightarrow Cr = 0,142$

For tanks with exchangers or buffer tanks, in the absence of data from the manufacturer, the cooling constant (Cr_{REF}) can be calculated according to the following formula proposed as a default value within TH-C (RT2005) rules:

$$Cr_{REF} = 3,3 \times Vs^{-0,45} \quad (Vs : \text{Volume of stored water in litres})$$

According to the formula above, the results of the calculation are presented in the following table:

Model	300	500	750	1000	1500	2000	2500	3000	4000	5000	6000
Cr_{REF}	0,267	0,209	0,171	0,148	0,126	0,107	0,100	0,094	0,080	0,072	0,067

We may observe that the insulation performances of our tanks are largely superior to those of reference.

As an example, on a 1500 liter tank ($\varnothing 950 \text{ mm}$), see below the evolution of the temperature of hot water inside the tank in relation to time, a characteristic cooling curve of the hot water, initially at 65°C , in a 20°C environment [exterior convection coefficient = $10 \text{ W}/(\text{m.K})$].

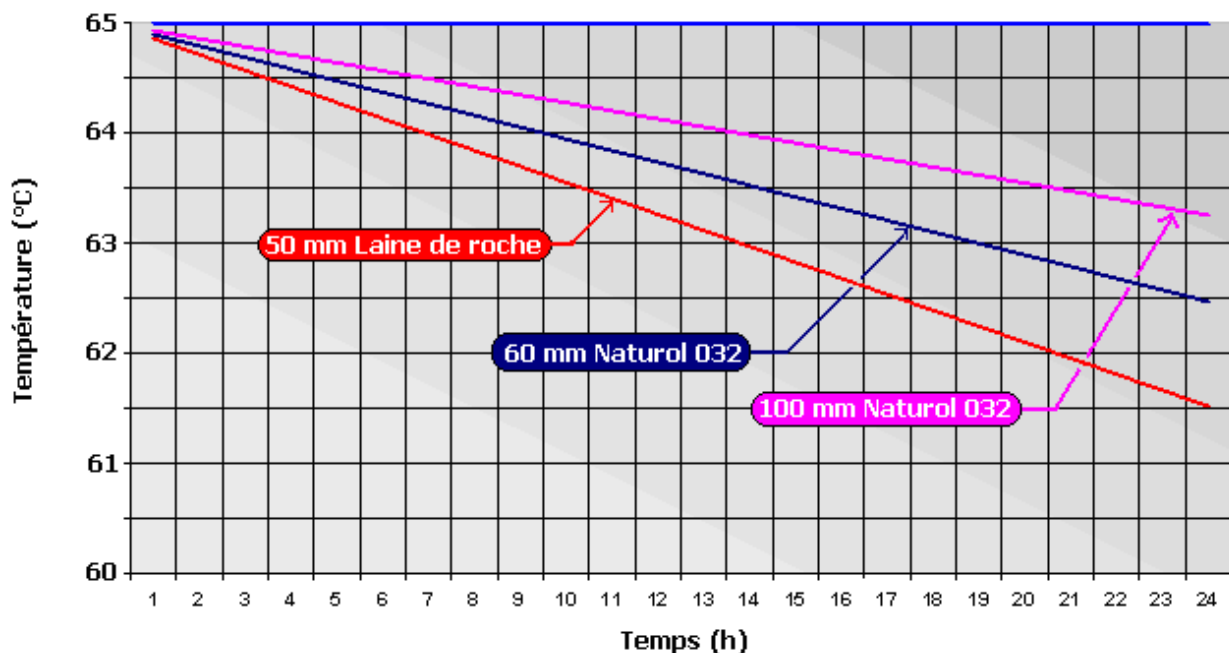

(NT: laine de roche = rock wool; temps = time)

Equipment (depending on version)

Electrical Equipment (*the most common equipment*).

The heating elements are usually armored electric heating elements (INCOLOY* pins), mounted on M77 threaded rings / DN40 coupling for electric elements up to 12 kW or on M77 threaded rings from 15 kW on.

The voltage used is 230 / 400 V (star coupling) up to 24 kW including and 400 V three-phase (triangle coupling) for 30 to 35 kW.

Up to and including 20 kW (or 30 A), the immersing heaters can be equipped with an integrated mini control box incorporating safety and regulation, allowing the use without an external power contactor.

* Incoloy 825 version up to 12 kW,

* Standard version in Incoloy 800 for unit power ≥ 15 kW and in 825 on demand.

Optional electrical equipment – Pocket Mounting

The tanks can also be equipped with electric heating elements that can be dismantled without draining the tank: they are heating cartridges with low load ratio [6 W/cm²] (1 x 230V – 50 Hz), located in a pocket made of stainless steel.

The electrical equipment includes 3 to 9 heating cartridges, being the equivalent to 1 to 3 heating elements. The power is 3 x 2000 W minimum and up to 9 x 3000 W maximum. The cartridges are star-coupled and need a feeding tension of 3 x 400 V, 50 Hz.

For any power, the heating cartridges can be equipped with a control box that includes safety and temperature regulation, with integrated power contactor.



NOTE

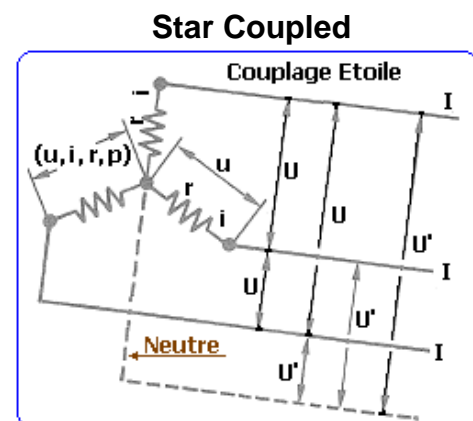
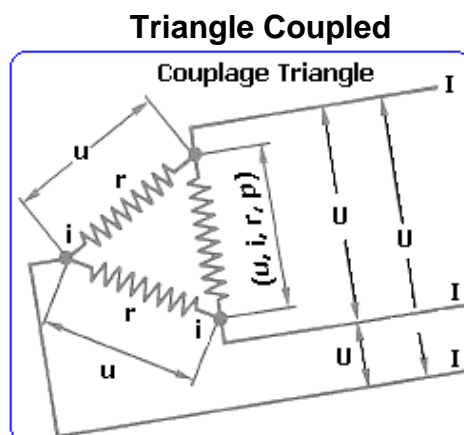

Calculation : - Total power $P = 3 p$

- Total power $P = 3 p$

Supply

- Three-ph. voltage $U = 230 \text{ V (=} u)$
- Intensity $I = P / (\sqrt{3} \times U)$
- u : nominal tension (230 V) of r
- p : nominal power of r
- r : nominal resistance

- Three-ph. tension $U = \sqrt{3} \times 230 = 400 \text{ V}$
- Intensity $I = P / (\sqrt{3} \times U)$
- $U' = u = 230 \text{ V}$ for $U = 400 \text{ V}$
- u : nominal tension (230 V) of r
- p : nominal power of r
- r : nominal resistance

U-Tube Heater

The removable U-Tube Heater is mounted on a $\varnothing 400 \text{ mm}$ manhole and/or on a $\varnothing 250 \text{ mm}$ nozzle, after fitting an asbestos-free fiber joint, using galvanized steel nuts and bolts class **8.8**. The tube bundle is made of stainless steel AISI 316L.

The standard operating conditions are:

- **Primary: 90/70 °C**
- **Secondary: 10/60°C**

for a heating duration of 1.5, 2, 2.25, 3, 3.25 or 4.25 hours according to the installed power and the tank volume.

Dome Mounting on $\varnothing 400 \text{ Manhole}$

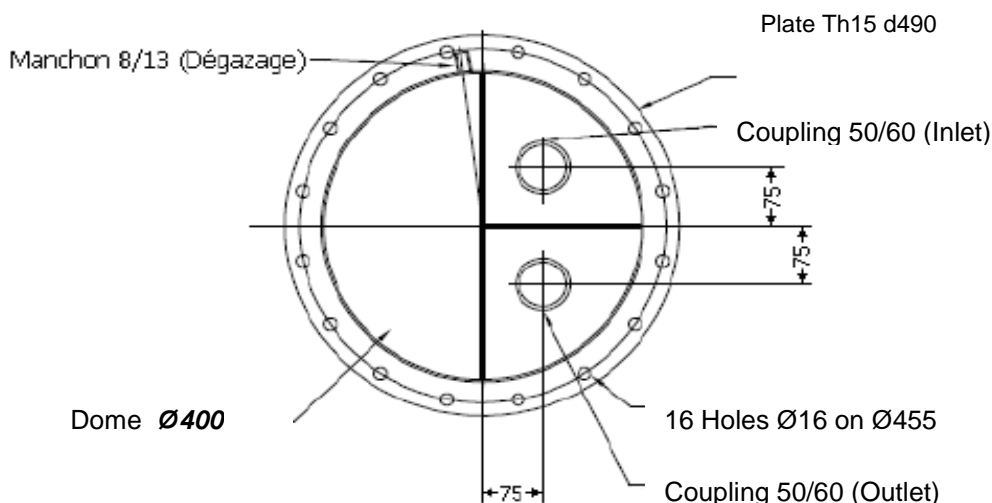

Ø250 Dome Mounting on Ø400 Manhole

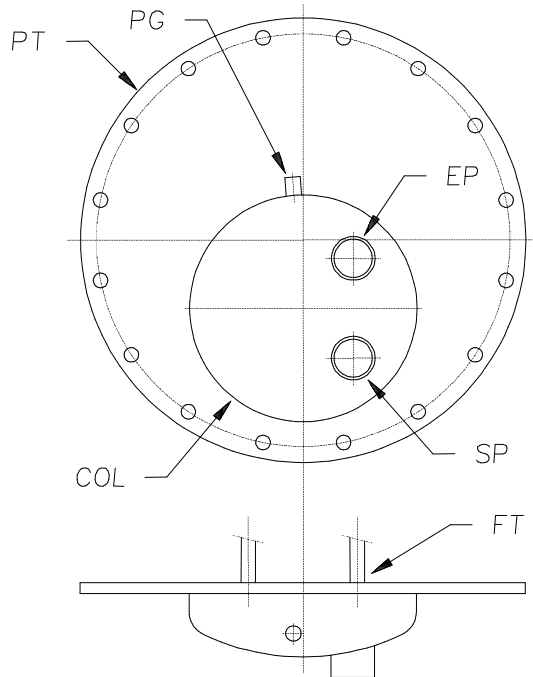

Parts List:

- PT- tube plate S235 Ø490
- PG- air vent
- EP- primary circuit inlet
- SP- primary circuit outlet
- COL- collector
- FT- stainless steel tube bundle

Schematic diagram of U-Tube Heater

The U-Tube Heater's power varies according to the primary and secondary functioning parameters (especially temperatures and flow). The indicated power is always the average power.



Warning!

Whatever the type of regulation, the temperature reading point on the tank must *IMPERATIVELY* be situated above the heating element.

INSTALLATION

General Warnings



Warning!

Our storage and production equipment must be installed with respect of trade practices, in conformity with the:

- ☞ Standards / regulations in force
- ☞ Recommendations of D.T.U. (particularly DTU 60.1)
- ☞ Instructions of this manual



DANGER!

This appliance must be exclusively destined for the use for which it was conceived. Any other use shall be considered as incorrect and potentially dangerous.



Attention!

The appliance must only be installed by a professionally qualified person who, under his own responsibility, can guarantee the respect of the standards/regulations in force..

Typical connection diagram for the installation (indicative)

See below the typical connection plan and recommendations:

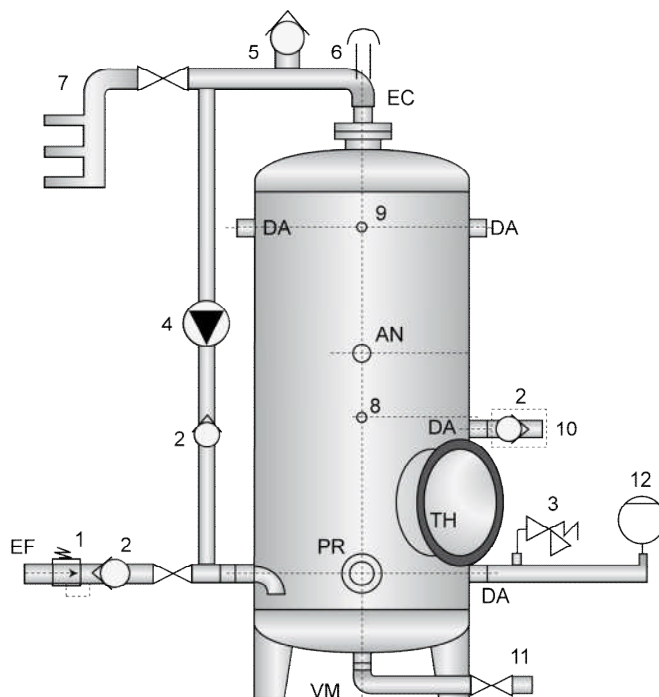

Key :

- 1- Pressure controller + anti-hammer
- 2- Non return valve
- 2'- For connection on loop return
- 3- Safety valve (non adjustable)
- 4- Circulation pump for homogenization
- 5- Vacuum-breaking system (on upper part)
- 6- De-gassing (on HW outlet)
- 7- Distribution network + anti-hammer
- 8- Regulation/safety thermostat
- 9- Thermometer
- 10- Loop return or **mandatory** cold water inlet for Hydrogaz
- 11- Drainage (VM in threaded union DN50)
- 12- Expansion system
- DA- Threaded couplings
- TH-Inspection manhole Ø400mm or (heating equipments, tube heaters, immersion heaters, pockets)
- AN- Coupling 40/49 for anode
- PR-Threaded ring M77 for immersion heater



Attention!

The typical hydraulic plan presented above is purely indicative. For dimensioning and configuration of the installation, it is necessary to approach a qualified consultant.



Attention!

Always provide, in correspondence with the safety valve rated at 7 bar, a connection to drains of the above valve (clearly visible and implemented via a funnel type siphon).



Attention!

It is necessary to install:

- at least one safety valve rated for a pressure of max 7 bars;
- an expansion system of a capacity adapted to absorb the water volume variations in the circuits connected directly to tank(s) due to heating and cooling.



DANGER!

In case of the absence of a connection to drains, the eventual working of the safety valve can cause damage to people, animals or objects, for which damage the manufacturer cannot in any case be held responsible.



Attention!

It is necessary to install:

- an air-bleed vent on the upper part of the tank in order to evacuate (or introduce) gas (air) during filling (or draining);
- an adapted de-gasser on the hot water outlet to capture the micro-bubbles and to evacuate them from the circuit.



Attention!

It is obligatory to install:

- a rapid drainage valve for the evacuation of sediments, according to the regulations in force;
- according to the configuration of the installation, a vacuum breaking valve on the upper part of the tank, in order to protect the tank from depression in case of accidental breaking of pipes causing drainage of the tank.



Attention!

Do not mix different metals favorable to electro-chemical couples – galvanic battery (e.g. Copper/Steel). Avoid particularly copper elements (tubes, couplings, bends, etc.) in upstream of the tank.



Attention!

Grounding is compulsory according to the regulations in force.

*** In order to prevent the permanent activation of the safety valve, it is strongly recommended to set the maximum service pressure to a value equal to the rated value minus 5 to 10%, i. e. between 6.30 and 6.65 bar.**

Some typical examples (indicative)

SERIAL

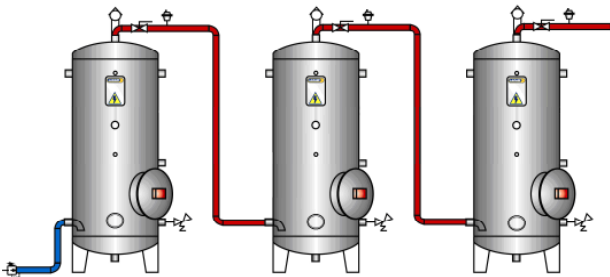

PARALLELE

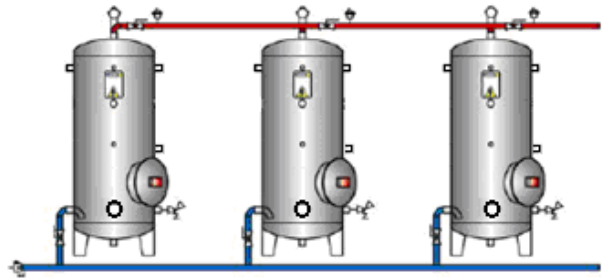

SERIAL PARALLELE

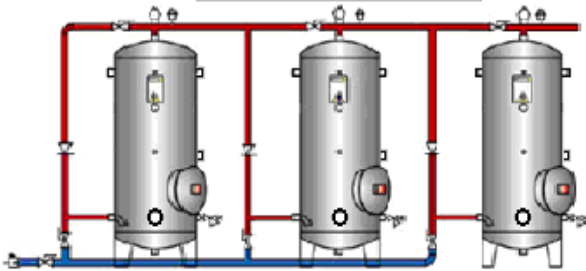

SERIAL HOMOGENISATION

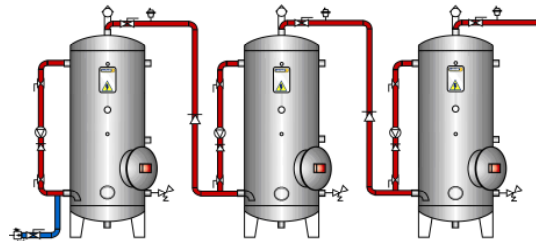



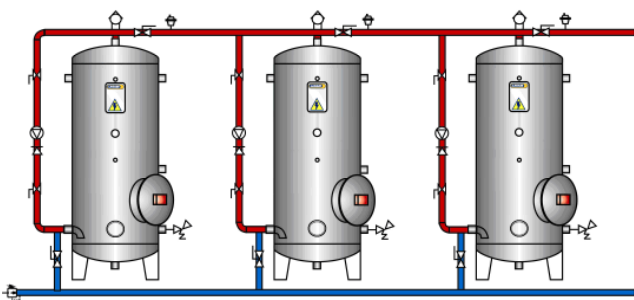

PARALLELE HOMOGENISATION

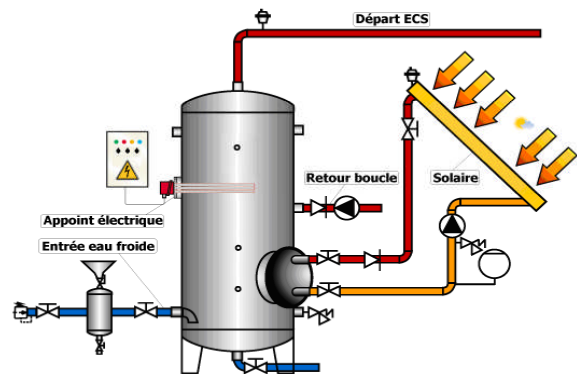





SOLAR HOT WATER + ELECTRIC TOP-UP



KEY :

-  De-gasser
-  Vacuum-breaker
-  Butterfly valve
-  Non-return valve

-  Pressure controller
-  Safety valve
-  Pump
-  Expansion valve

Tightening of the nuts and bolts of the manhole cover

The mounting of the cover for the manhole (plate/companion flange) and the assembly of the nuts and bolts is carried out in the factory following a pre-defined procedure.

However, during transportation or/and handling, the nuts and bolts may become un-tighten because of vibrations and other factors (temperature, pressure, etc.). It is therefore recommended to follow the safety procedures described below:

- ensure that the bolts are tightened to the specified torque after installing equipment on site as they may have loosened during phases of storage and / or transport
- at commissioning, ensure that there are no leaks,
- after one month of use, recheck the tightening torque and absence of leaks.

As an example, here are some recommended tightening torques ($\mu = 0,2$):

Type TH	TH400	TH400	TH400	TH500	TH500
Gasket (3 mm)	m=2,5 ; y=12	m=2,5 ; y=12	m=2,5 ; y=12	m=2,5 ; y=12	m=2,5 ; y=12
Ps (bar)	7	6	4	7	4
*Cs (Nm)	150	150	150	180	180
**Csm (Nm)	155	155	155	232	232

* C_s : recommended tightening torque (washer on nut side + dry mounting)

** C_{sm} : maximum tightening torque (washer on nut side + dry mounting)

TH : manhole



Warning!

It is highly advisable to use a new gasket (replace the used gasket) at the reassembly of the manhole after each opening of the tank.

Filling

Once all hydraulic connections of the installation have been made, proceed to water filling through the cold water inlet. Make sure that the air bleed valve is open during filling.

First Commissioning

The first commissioning must always be carried out by a professionally qualified person. Lacaze Energies declines all responsibility in case of damages caused to persons, animals or objects, following the failure to comply with this instruction.

Before connecting the appliance to the heating installation, carry out a thorough washing of the piping with an adequate product with the purpose of eliminating all impurities such as filings, welding, various debris, oil and grease which could be present in the circuits.

Never use solvents to rinse the hydraulic piping; this could irretrievably damage the installation and/or components.

The heating elements should never be commissioned if the tank is not entirely filled with water. Ensure that the tank is completely filled by drawing water (for instance from a drawing point at the hot water outlet) before the first heating.



DANGER!

Connecting to electricity without filling the tank leads to irretrievable destruction of the immersion heating elements. (Damage not covered by warranty!)

Check the presence and the correct installation of the safety and regulation devices and check their correct functioning, particularly of the thermostat and the safety valve. It is to be noted that this adjustment is only approximate and further adjustments need to be made to obtain the desired temperature.

Recommendations and requirements

- Install the water heater as close as possible to the place of use, protected from frost, allowing for an easy access for dismantling and eventual replacement of the tank.
- ***It is imperative to allow sufficient clearance for easy dismantling of the accessories such as the U tube heater and the electric heating elements (minimal clearance equal to the diameter of tank).***
- All necessary precautions must be taken against any risk likely to cause damage to the lining (e.g. shocks) during transportation, handling and maintenance operations (e.g. high pressure water jets, abrasives etc.) to the tanks.
- The evacuation from the valve must be connected to a drainage system by a "funnel-type" connection, to visualize the functioning of the valve.
- Before final commissioning, we strongly advise you to rinse the tank to eliminate all wastes or deposits. Then drain the tank after the first heating or disinfect it using authorized compatible products. When draining the tank, make sure there is sufficient air admission to avoid tank depression.
- Check carefully that the anode tap valve (latest generation) is closed once the tank is filled with water.
- To preserve the longevity of the tank, it is recommended that these instructions be followed:
 - Limit the temperature of use to 80 °C.
 - Do not soften the water below TH 8°F, maintain to TH<15°F.
 - Reduce the working pressure and its variation to the lowest possible.
 - Ensure that there is a good connection between tank body and magnesium anode.
- Ensure that the pressure is constant and that there is no strong variation ($\Delta P < 1\text{bar}$).
- Do not install an isolation valve between the tank and the safety valve.
- Do not use adjustable safety valves.
- Only use valves of dimensions adapted to the installed power and/or to the flow.
- For electric connections:
 - The circuit breaker against power overloads, the relay contactor and the section of the power supply cables must be chosen in conformity with NF C-15 100.
 - Provide an automatic cut-off protection device in case of insulation fault, a differential device or other according to the working of the « Neutral ».
 - Check the tightening of electric connections before connecting to electricity.

CHECKING AND MAINTENANCE



Warning!

The checking and maintenance carried out under general trade practices and at regular intervals, as well as the exclusive use of original spare parts supplied by the manufacturer, are essential to obtain a correct and faultless functioning and to ensure an optimal lifespan for the tank.



DANGER!

The absence of regular checking and maintenance can cause material or personal damages.

Checking during periodic maintenance serves to determine the effective state of the appliance compared to the desired optimal state. This can be carried out through appropriate measures and visual controls.

The frequency of the maintenance depends on the nature of the stored water and the flow (consumption). Consequently, the maintenance frequency must be determined by the user according to each particular type of use and without exceeding the maximum periods mentioned below:

- Handle the safety valve(s) (once a month)
- Check the function of the degasser (once a month)
- Check the state of the anodes and replace them before reaching 60% wear – *recommended* - (twice a year)
- Open fully the drainage valve completely (once a week)
- Check and validate the water quality (once every 3 months)
- Examine and clean the heating elements (once to twice a year)
- Maintenance of the water treatment system (4 times a year)
- Cleaning, de-scaling and disinfection of the tank in view of the fight against Legionnaire's disease (at least once a year)

WARRANTY

Our **LACAZE ENERGIES** « Preference RC951 series» tanks are guaranteed, from the date of delivery, against perforations in continental climatic conditions and for the duration specified on the warranty certificate delivered with the appliance:

- * **Standard shell : 5 years.**
- * **Equipment + accessories : 1 year.**

This warranty is limited to the exchange, repair or replacement (supply) in our factory at Leyme (France 46) of parts acknowledged to be defective by our technical service, according to our general conditions of sale. All other damage, transportation, labor costs which may result, are excluded.

The replacement, repair or modification of parts during the period of warranty will not result in a prolongation of the period of warranty and cannot give rise to any indemnity for diverse costs or any prejudices.

Deterioration to appliances due to the following is excluded from the warranty:

- Bad electrical connection, and in particular:
 - Absent or insufficient circuit breaking power.
 - Incorrect wiring of remote controls and switches.
 - Power surges.
 - Incorrect grounding of the tank and/or faults or absence of insulation.
- Supply water pressure superior to nominal pressure and/or excessive variation of pressure ($\Delta P > 1 \text{ bar}$).
- Bad handling during assembly and installation (particularly connecting to electricity without prior filling of the hydraulic circuit; mechanical shocks).
- Overpressure resulting from the use of security units of which the rating is superior to the service pressure.
- Overpressure due to the absence, or insufficiency, or bad functioning or incorrect assembly, of the security units, particularly the valve(s).
- Depression resulting from the absence of sufficient air during draining.
- Depression in functioning $> 0, 1 \text{ bar}$ or 100 mbar .
- Faults in maintenance of the heating elements or the safety devices.
- Incorrect or inappropriate connections of the piping to the attached accessories (see paragraph § III.2).

- Corrosion of the orifices for the entry or exit of water, resulting from defective or inappropriate connection (faulty water tightness/steel–copper contact).
- Insufficient quality of the supply / top up water (see paragraph § I.3 below).
- Corrosion due to insufficient or absent degassing.
- Corrosion due to organic and/or metallic deposits coming from the hot water distribution network (loops) or cold water supply (water feed).
- Bad contact or absence of connection between the tank shell and the anode.
- Faulty maintenance of consumable anode(s) (non replacement before advanced wear: remaining weight(s) <20% of initial weight of anode(s) after descaling).
- Generally, failure to comply with this instruction manual.

**Attention!**

Please consult us for the limits of use of a continuously chlorinated product (e.g. preventive treatment against Legionnaire's disease) and curative (shock) treatment for all tanks and/or stainless steel equipment.

The clauses of this certificate of warranty do not exclude the buyer from his legal rights relating to defects and hidden vices, under the conditions of article 1641 of the Civil Code and of those related to responsibility for faulty products.

PACKAGING / TRANSPORT / STORAGE / HANDLING

Packaging

Standard « **Preference** » tanks are supplied completely assembled (except anode(s)), wrapped with plastic film and secured on a pallet suiting their dimensions and dispatch method. Wrapping is detailed in the offer.



Warning!

After unwrapping the tank, ensure its perfect integrity. The elements of packaging must be sorted and disposed of according to their nature with a view to protection of the environment.

Transport / Storage

The appliance must be transported and stored in its original packaging until its installation.

Conditions of storage:

- Surrounding temperature: between 5 and 50°C (standard appliance)
- Relative humidity (HR): 30 to 80% (no condensation)

Handling



Warning!

The appliance must be handled by qualified personnel using adequate lifting equipment:

- ***using a pallet transporter (attention to stability !)***
- ***by its lifting rings using a traveling bridge or a crane having compatible lifting capacity. The handling slings must be adapted to the weight and in good condition.***

The appliance must be handled « EMPTY » and without any complementary accessories not delivered and mounted by the manufacturer.

During handling avoid any manoeuvre that risks producing lateral shocks to the tank.

The tank must be posed smoothly on the ground.

On site handling will be carried out by the client.

Cur Ref: HL/M1203020
Test Report: MAT/LAB 7908



19th October 2012

Lacaze Energies SAS,
Zone Industrielle, BP 2,
45120,
Leyme,
France

WATER REGULATIONS ADVISORY SCHEME (WRAS)
MATERIAL APPROVAL

The material referred to in this letter is suitable for contact with wholesome water for domestic purposes having met the requirements of BS 6920-1:2000 'Suitability of non-metallic products for use in contact with water intended for human consumption with regard to their effect on the quality of the water'.

The reference relates solely to its effect on the quality of the water with which it may come into contact and does not signify the approval of its mechanical or physical properties for any use.

COATINGS, PAINTS & LININGS – FACTORY APPLIED METAL COATINGS

5028

RC851. Factory applied, mustard coloured, two part epoxy coating consisting of a base and hardener. Mix, apply and cure as per manufacturer's instructions. For use with water up to 85°C.

APPROVAL NUMBER: 1005531
APPROVAL HOLDER: LACAZE ENERGIES SAS.

The Scheme reserves the right to review approval. This approval is valid between May 2010 and May 2015.

An entry, as above, will accordingly be included in the Water Fittings Directory on-line under the section headed, "Materials which have passed full tests of effect on water quality".

The Directory may be found at: www.wras.co.uk/directory

Yours faithfully



Jason Furnival
Approvals & Enquiries Manager
Water Regulations Advisory Scheme

Water Regulations Advisory Scheme Ltd.
30 Fern Close, Pandy-Fan Industrial Estate,
Oakdale, Gwent NP23 5EH, UK.
Tel: 01495 248464. Fax: 01495 236280
E-mail: info@wras.co.uk Website: www.wras.co.uk

The Water Regulations Advisory Scheme Ltd.
is a registered charity with the following details:
Registered Office: 30 Fern Close, Pandy-Fan Industrial Estate,
Oakdale, Gwent NP23 5EH, UK.
Registered in England No. 1042982.
Registered in Wales No. 1042982.
Charity No. 1042982.

Recommendations DTU 60.1 – Additif N° 3

Elements of analysis	UNIT	Case of compulsory treatment	Treatment type	Desired value	Observations
Temperature	°C	---	---	---	
pH	U	< 7,2	A	> 7,2	
TH	°f	TH < 6 or TH > 25	B C	8 to 15	
TAC	°f	TAC < 6 or TAC > 30	B C	10 to 20	
Mg ⁺⁺	°f	> 4	C	< TH / 5	
Ca ⁺⁺	°f	***	C	***	Note (1)
CO ₂ free	mg/l	> 30	D	< 10	
O ₂ dissolved	mg/l	> 9	D	6 to 9	
Cl ⁻	°f	> 7	E	< 3	
SO ₄ ⁻⁻	°f	> 9	E	< 5	
NO ₃ ⁻	°f	> 1	E	< 0,5	
Resistivity at 20°C (ρ)	Ω x cm	< 2 000	E	2 500 to 3 000	Note (2)
Na ⁺	°f				Note (3)
Fe ⁺⁺	mg/l				Note (4)
Treatment Type:					
A :	- Degassing + Eventual Neutralite and/or Film-former product				Note (5)
B :	- Neutralite or similar and/or Film-former product				Note (5)
C :	- Softening or Partial demineralization				
D :	- Degassing				
E :	- Total or partial demineralization, and/or Film-former product				Note (5)
Notes:					
(1)	- The value Ca ⁺⁺ was not indicated; this can be obtained by difference between TH and Mg ⁺⁺ .				
(2)	- Approximate calculation : $\rho = 750\,000 / R_s$ (R _s : dry residue at 105°C in mg/l)				
(3)	- Na ⁺ dosage is necessary in case C				
(4)	- Drinkability norms: Fe total ≤ 0,2 mg/l)				
(5)	- Film-former product: a treatment with silico-phosphate salts against corrosion				

Note : 1 °f = 0,2 milli equivalent (meq) per liter.

Specification of the necessary quality of supply water

APPLIANCE / EQUIPMENT	MINIMAL QUALITY OBTAINED
HW Tanks in coated steel	_ DTU 60.1
Hydrogaz (HDZ) Exchanger	_ IR between 6 and 7 at the temp. of usage _ Cl ⁻ < 100 mg/l (Si T°C < 85°C)
HDZ Exchanger + Tank coated steel RC951	_ IR between 6 and 7 at the temp. of usage _ Cl ⁻ < 70 mg/l _ SO ₄ ²⁻ < 96 mg/l _ Provide a supplementary anode on the inferior part of tank
Immersion heater in Incoloy 800	_ TH < 15 °f ; _ Cl ⁻ < 30 mg/l ; _ T < 95 °C
Immersion heater in Incoloy 825	_ TH < 15 °f ; _ Cl ⁻ < 70 mg/l ; _ T < 95 °C
Cartridges version Pocket	_ TH < 25 °f ; _ Cl ⁻ < 70 mg/l ; _ T < 95 °C
Tube Heater	_ Cl ⁻ < 70 mg/l ; _ T < 95 °C
Safety Organs (valve, thermostat etc.)	_ DTU 60.1 _ TH < 15 °f
Stainless steel tanks	_ Cl ⁻ < 70 mg/l ; _ T < 95 °C
Plate Exchangers PLAKEO	_ TH < 15 °f ; _ Cl ⁻ < 70 mg/l ; _ T < 95 °C
BIP-TIC System	_ TH < 25 °f _ Cl ⁻ < 70 mg/l ; _ T < 95 °C

Note: Please consult us for the limits of use of a continuously chlorinated or similar product (e.g. preventive treatment against Legionnaire's disease) and curative treatment (shock) for all tanks and/or stainless steel equipment.

**TANK FOR PRODUCTION AND STORAGE
OF DOMESTIC HOT WATER**

INSTALLATION AND OPERATION MANUAL
([IU-0023-EN-201004](#))

Preference RC 951 range