

# HEATING EXPANSION VESSEL

Technical datasheet Nr 70

LACAZE ENERGIES heating expansion vessels are specially designed to ensure the proper functioning of closed heating systems. The vessels are completely welded, thus particularly resistant.

## • TECHNICAL SPECIFICATIONS:

- System operating pressure: -10°C / +90°C
- Membrane: Synthetic rubber SBR (temperature up to +70°C max.)
- Designed for closed heating systems
- Colour: Red

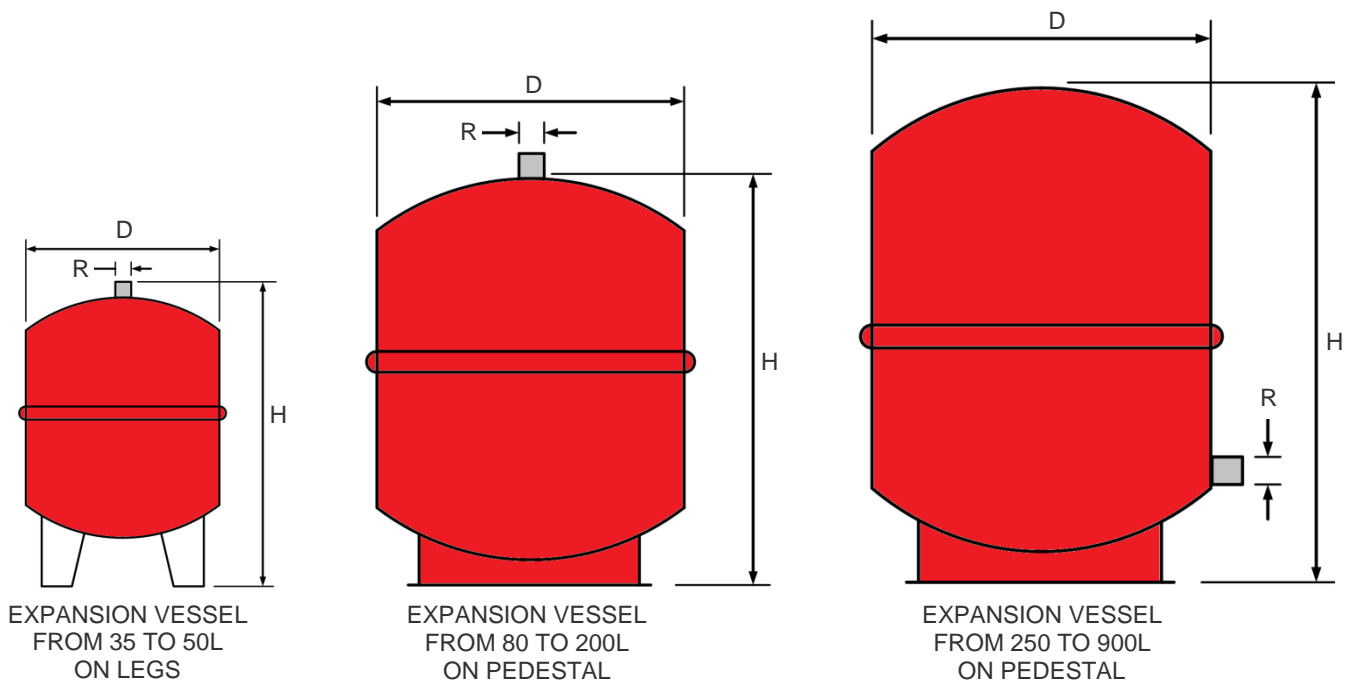

Designation	Reference	Height H (mm)	Diameter D (mm)	Connection R	Factory precharge (bar)	Max. operating pressure (bar)
35L	70010146001	521	368	3/4"	1.5	3
50L	70010146002	557	418	3/4"	1.5	3
80L	70010146003	608	450	3/4"	1.5	6
105L	70010146004	665	500	3/4"	2	6
150L	70010146005	897	500	3/4"	2	6
200L	70010146006	812	600	3/4"	2.5	6
250L	70010146007	957	630	3/4"	2.5	6
300L	70010146008	1105	630	3/4"	2.5	6
400L	70010146009	1450	630	3/4"	2.5	6
500L	70010146010	1340	750	1"	2.5	6
600L	70010146011	1555	750	1"	2.5	6
700L	70010146012	1755	750	1"	2.5	6
800L	70010146013	1855	750	1"	2.5	6
900L	70010146014	2105	750	1"	2.5	6

Note: Complies with Pressure Equipment Directive PED 97/23/CE

Document that can be susceptible to changes