

Installation and commissioning

DHW MODULE

PREPAC

(IU-0002-FR-200906)

Attention !

This document does not concern the associated tank (Ballon)

SUMMARY

WARNING	3
GENERAL CHARACTERISTICS	4
PLATE EXCHANGER	4
MOUNTING OF PLATES	6
CONNECTIONS	8
COMMISSIONING / MAINTENANCE	9



WARNING

Note concerning the elaboration and publication of this manual :

This manual was elaborated and published under the direction of LACAZE ENERGIES. It covers the most recent features and descriptions of the product. The manual content and the product features may be modified without prior notice.

The company LACAZE ENERGIES reserves the right to modify without prior notice the features and elements contained in the following pages. The company LACAZE ENERGIES will not be responsible for any damage (including consecutive damage) caused by reliance on the presented elements. This includes, but is not limited to, typing mistakes and other errors linked to the publication

© LACAZE ENERGIES

Please read carefully:

- This instruction manual is an integral part of the product and must be given to the final user.
- The appliance was manufactured for the storage of hot or cold water, used in a closed circuit. Any other use shall be considered as inappropriate and dangerous.
- The appliance must not be installed in humid locations (H.R. \leq 80%). Protect the appliance from water or other liquid splashes to prevent damage to the components.
- Installation must be carried out in conformity with the rules, regulations and standards currently in force, respecting the instructions of the manufacturer, by a qualified professional.
- In the case of the equipment being sold or transferred to another user, this manual must accompany the equipment, so that the new user and the installer can consult it.
- If the equipment is not used during a period of below-freezing conditions, we request that it should be drained completely. The manufacturer declines all responsibility for any damage due to frost.
- We recommend that these instructions be read carefully, and advise the exclusive use of spare parts supplied by the manufacturer, in order to obtain the best service from the product and the acknowledgement of the appliance warranty.

CHARACTERISTICS

The DHW Module "**Prepac**" is a domestic hot water production system consisting of :

- A plate heat exchanger with demountable plates, with a high exchange coefficient.
- A single-phase 230V circulator, simple or double.
- Stainless Steel pipes.
- Two isolation valves.

This system will provide an important quantity of domestic hot water at a temperature of 45 to 60°C.

PLATE EXCHANGER

Convention

As with any plate exchanger in general, there is a hot fluid which is being cooled and a cold fluid which is being heated.

Throughout this document we will refer to the hot water fluid circuit as the **Primary Circuit**, and the cold water fluid circuit as the **Secondary Circuit**.

Composition

The plate exchanger is made up of a series of plates held together between two supporting plates, one fixed, the other mobile. The supporting plates are connected by braces and held in position by two tension rods.

On the fixed plate there we find the connecting orifices:

The two fluids flow between the plates, whose judicious combination, using joints, allows the perfect partitioning of the circuits, fully guaranteeing their independence.

Materials

The Plates :

The plates are made of AISI 316 L stainless steel [Z6 CND 17.12], so providing excellent resistance to corrosion (for Cl⁻ ≤ 70 mg/l contents).

MODEL	Thickness (mm)	Distance (mm)	Surface (m ²)
C12	0.5	3.10	0.032

The gaskets :

These have two main functions:

- To ensure that the exchanger is water tight.
- To separate the primary and secondary circuits.

A double gasket around each plate orifice prevents mixing of the fluids. If a gasket is faulty, the liquid will leak towards the exterior of the exchanger.

PLAKEO exchanger plates are equipped with Nitrile (P) gaskets which are regularly used in heating appliances for temperatures ≤ 100°C

The circulator

Brand Grundfos type UPS operates up to 100°C.

The Frame :

Made of S235JRG2 carbon steel, covered with 2 coats of epoxy paint (thickness 15 mm).

MODEL	Frame weight (kg)	Operating Pressure (bar)
C12	18	10

Tension Rods and Braces :

In electro-galvanized steel class 8.8 for the threaded parts and bolts.

	C12
BRACES	2 x Φ15
TENSION RODS	6 x M12

Main Range of Exchangers:

Exchanger Power (kW)	Primary 90°C		Sec. 10/55°C
	Flow (m ³ /h)	Head Loss (mCE)	Flow (m ³ /h)
41	1,26	2,9	0,79
49	1,26	1,69	0,94
66	2,02	2,7	1,26
77	2,12	2,12	1,48
87	2,41	2,7	1,66
94	2,59	3,1	1,8
100	2,52	2,2	1,91
106	2,48	1,67	2,02
136	3,71	2,88	2,59
143	3,89	3,16	2,74
154	3,89	2,61	2,95
222	5,83	3,09	4,25
252	6,44	2,96	4,82
266	6,77	3,26	5,08
301	7,6	3,06	5,76
332	8,24	3,06	6,34

PLATE ASSEMBLY

Refer to the following figures and tables to visualize the correct assembly of the plates.

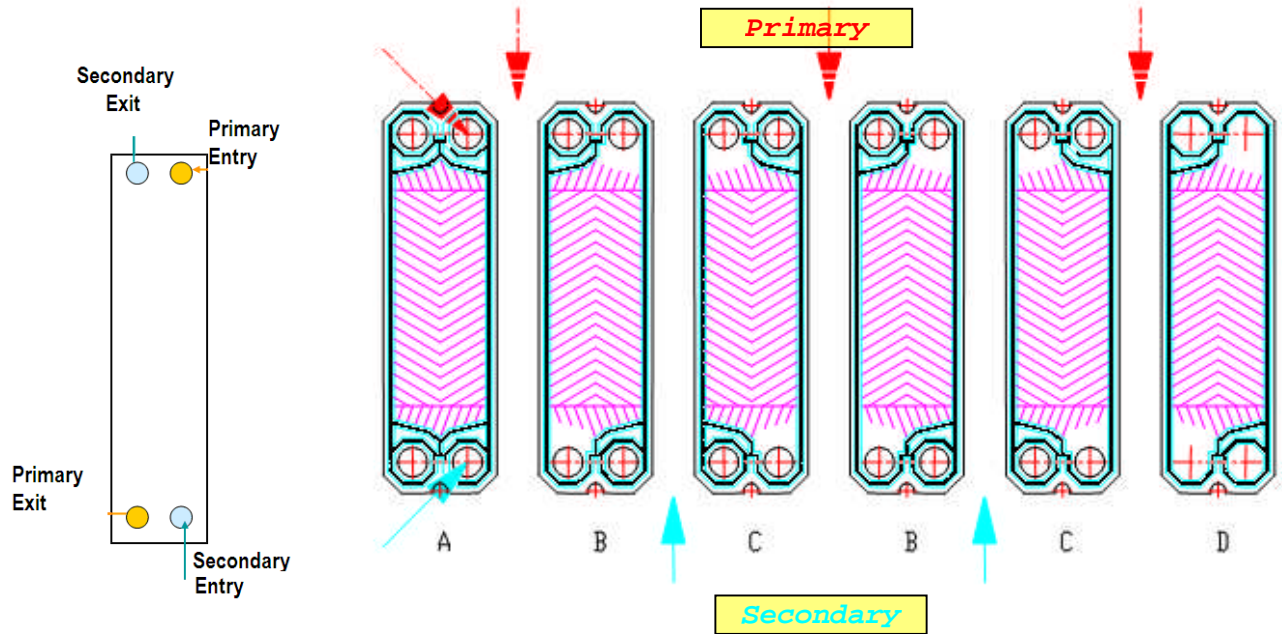

Plate assembly diagram for C12 Plates - Right -

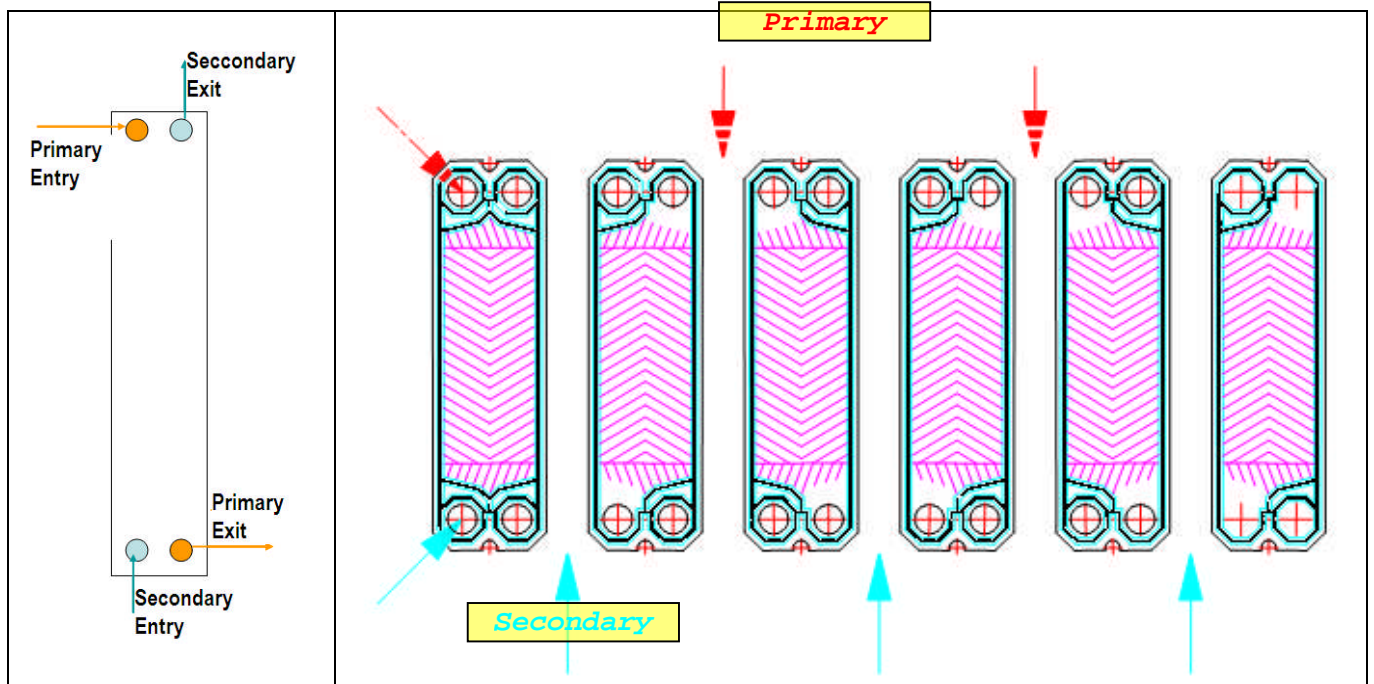

Plate assembly diagram for C12 Plates - Left -

Reminder :

- N_t total number of plates
- N_a front plate with 4 holes and a gasket around each orifice.
- N_d back plate, without holes.
- N_b intermediary plate (even number).
- N_c intermediary plate (odd number)

We have the following equalities :

Number of plates "EVEN" :

- $N_a = 1$
- $N_b = N_t / 2 - 1$
- $N_c = N_b$
- $N_d = 1$

Number of plates "ODD" :

- $N_a = 1$
- $N_b = (N_t - 1) / 2$
- $N_c = N_b - 1$
- $N_d = 1$

Tightening Code:

The spacing of the plates must be:

$$E = N_t \times 3,1$$

 **Remark :**

Only in case when the number of plates is odd the distribution of primary and secondary channels is identical. In all cases, it is necessary to ensure that the entries and exits of each fluid are correct.

To know the exact characteristics of the model supplied, please consult the identification sticker (nameplate) placed on the heat exchanger (example below).

Please note that this is only an example.



Z.I. – B.P. – 46 120 LEYME
MODULE DE PRODUCTION D'EAU CHAUDE
 PREPAC

MODEL	=	GTI26-12p13s/4
FRAME	=	LEFT
PUMP N°	=	4
NO. PLATES	=	26
PRIMARY FLOW	=	1.42 kg/s
TEMPERATURE	=	90 °C
ENTRY/EXIT	=	S4/S2
NUMBER CANNELS	=	12
HEAD LOSS	=	30.9 kPa
SECONDARY FLOW	=	0.86 kg/s
TEMPERATURE	=	10-60 °C
ENTRY/EXIT	=	S3/S1
NUMBER CANNELS	=	13

HYDRAULIC CONNECTION

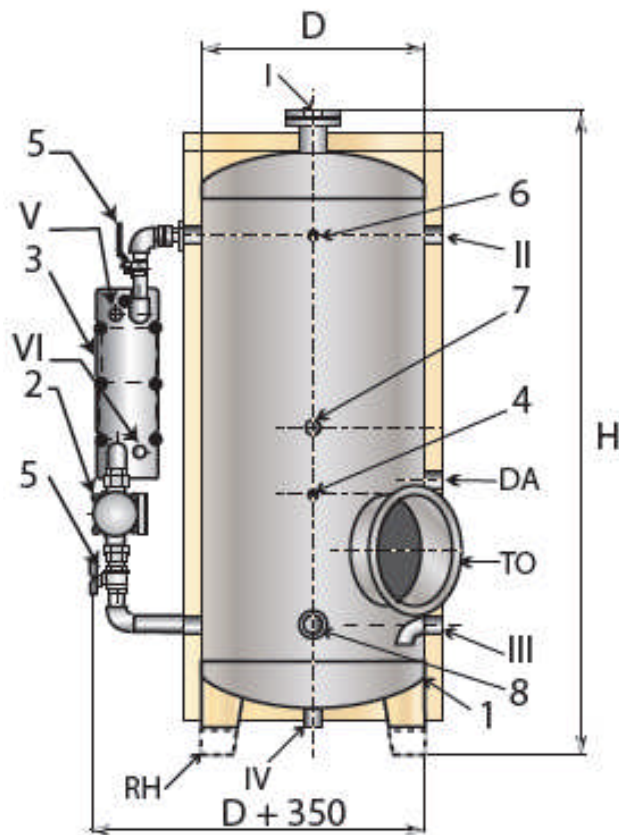

- 1 Tank
- 2 Secondary circuit circulator
- 3 Plate Exchanger (DN25 couplings)
- 4 Coupling 15/21 for thermostat
- 5 Isolation valves
- 6 Couplings 15/21 for thermometer
- 7 Coupling 40/49 for anode
- 8 Threaded boss M77 for immersing heater
- I Hot water Outlet
- II Loop return
- III Cold water inlet (baffle)
- IV Drainage
- V Primary Entry Exchanger
- VI Primary Exit Exchanger

Indicative diagram for connecting the PREPAC Module

Feed the Module with primary fluid in accordance with the nameplate (minimal flow and entry temperature).

Connect electrically the secondary circulator (pump) with a cable with a section adequate for the power absorbed (see motor nameplate).

⚠ Warning :

In all cases we specifically do NOT recommend the use of the contact for regulation of the thermostat to command the circulator because it makes sense to maintain the circulation of water between the plates even in the absence of withdrawal, to prevent scaling of the exchanger.

Provide line protection following standards and / or regulations at the place of installation.

Connection to a grounded outlet (earth) is compulsory.

It should be noted that the supplied circulator is provided with an embedded thermal protection **Ipsotherm** within the motor. This thermal protection is generally complemented by a fuse protection (short circuit).

COMMISSIONING / MAINTENANCE

Commissioning

It is essential to provide isolating valves on the 4 exchanger outlets.

It is also necessary to provide an expansion system for the fluids used in a closed circuit (primary circuit). Always provide safety valves for each of the circuits.

The air must be bled from the pipes. We advise you to fill the two circuits simultaneously. Always avoid filling the system too rapidly and the 'water hammer' effect, which could affect the standing to pressure of the exchanger.

Check the entry and exit temperatures for each of the two fluids. If necessary, adjust the respective flows by using the regulation valves, in order to obtain the required temperatures. Note the values obtained for temperature and head loss (decrease in pressure) in the exchanger maintenance booklet.



Warning !

Before closing the isolation valves « 5 » of the PREPAC, make sure that the feed on Primary is stopped !

Maintenance

The system is unlikely to become clogged up as long as fluids compatible with plate exchanger technology are used (**water TH< 15°F**). Systematic maintenance of the exchanger is not necessary if this rule is followed.

However, regular monitoring of the air vent valves and safety shut-off devices is necessary.

Careful monitoring of exchanger head loss and the respective temperatures of the In /Out fluids is essential.

In fact, if clogging occurs, there will be a noticeable increase in head loss (ΔP), due to reduction of the section of the fluid passage, as well as an important variation in the ΔT for the operating conditions of the corresponding clogged circuit (variation of the exchange coefficients).

Please note however that variations in exchanger performance do not always mean that it is clogged. It is always necessary to check the entry temperatures of the fluids and the flow rate before reaching a conclusion, as they have a great influence on exchanger performance.

It is strongly recommended that the inlets and outlets for each fluid are equipped with thermometers and monometers which indicate the correct functioning of the appliance as well as flow meters on each of the inlets.

If clogging is discovered, the exchange surfaces must be cleaned

Before opening the exchanger, ensure the following instructions are observed:

- Let the exchanger cool down for as long as necessary. Make sure you isolate hydraulically the primary and secondary circuits.
- Open the exchanger and mark the plates.

When removing the plates, wearing of gloves is recommended!!

If two or more plates are stuck to each other they need to be separated carefully, so that the gaskets remain attached to the correct plate. The exchange surface should then be rinsed with a water jet and scrubbed with a nylon (or equivalent material) brush. Take care not to damage the gasket. If necessary, use a nitric acid solution at 5%, then rinse abundantly.

 ***Important : Concentrated nitric acid can seriously damage the skin and mucous membranes! Great care is recommended when handling these solutions as well as the wearing of protective goggles and gloves.***

- A partially or completely detached gasket must always be glued back before replacing the plates.

- Reassemble the plates in the same order and same position (top/bottom), respecting the tightening values given (see "**Exchanger**").
- Tighten the plates in a regular manner (symmetrically and in parallel). In practice, the 4 tension rods at the extremities should be removed first and replaced last.

Nomenclature : (indicative, may vary between frame “left” and frame “right”)
(from bottom towards the top of the tank)

1 SS coupling FF DN 50 / 50mm
1 reduction MF DN 50/25
1 nipple MM DN 25
1 isolation valve DN 25
1 nipple MM DN 25
1 union fitting 2 parts DN 25
1 SS coupling MF DN 25

When DN20 circulator used

1 reduction MF DN 20/25
1 union fitting 2 parts DN 20
1 circulator
1 union fitting 2 parts DN 20
1 reduction MF DN 20/25

When DN25 circulator used

1 union fitting 2 parts DN 25
1 circulator
1 union fitting 2 parts DN 25

When DN32 circulator used

1 reduction MF DN 32/25
1 union fitting 2 parts DN 32
1 circulator
1 union fitting 2 parts DN 32
1 reduction MF DN 32/25

Plate Exchanger :

1 fixe frame with entry /exit for primary/secondary fluid
1 mobile frame
2 braces
6 tension rods
1 set of plates

1 SS pipe DN 25
1 SS bend MF DN 25
1 isolation valve DN 25
1 boss MM DN 25
1 reduction MF DN 50/25
1 SS coupling FF DN 50 / 50mm

**MODULE FOR THE PRODUCTION
OF DHW**

Prepac

INDICATIVE TECHNICAL INSTRUCTIONS
(IU-0002-FR-200906)